

Design and Experimental Investigation of Portable Solar Thermoelectric Refrigerator

S.M.A. Rahman*, A. Sara, R. Asmaa, S. Rasha

Sustainable and Renewable Energy Engineering, University of Sharjah, Sharjah 27272, United Arab Emirates

Abstract

The aim of this project is to design a portable solar thermoelectric refrigerator for people living in remote areas, or outdoor applications where electric power supply is absent. The design of the solar-powered refrigerator based on the principle of the thermoelectric module to create a hot side and cold side. Solar PV module is used to supply electrical energy to the thermoelectric module to generate hot and cold effects for heating and cooling application. A well-insulated rectangular container made of aluminum is used as a cooling chamber. To enhance the cooling effect, heat sinks and electric fans are added to the hot side to cool down the thermoelectric modules. The system was able to reach 4°C in the cold surface of the TEM and 10°C as the refrigerant temperature and 30°C in hot chamber with 0.66 COP. An economic analysis is carried out to study the viability of this novel technique. Economic analysis reveals that the system has sufficient amount of saving due to renewable source of energy which is free and lower maintenance cost. One more major advantages of the proposed refrigerator is its longer lifetime that might reach up to 40 years

Keywords: Solar PV Module, Refrigerator, Thermoelectric Module, COP, Economic Analysis

1. Introduction

Air conditioning and refrigeration are one of the greatest engineering achievements developed in the 20th century. These achievements have been used in many fields to improve the quality of our lives and make it more comfortable and enjoyable.

However, it is well known that the energy consumption for refrigeration and cooling system is increasing and has currently reached to 15% of the total electricity consumption in the world [1]. Refrigeration and air conditioning have a huge impact on the environment as they affect the stratospheric ozone which is primarily linked to release of ozone-depleting refrigerants as well as global warming, atmospheric pollution and worldwide shortage of energy [1]. A potential solution is to reduce these environmental issues by using an alternative technique for cooling and heating. Therefore, effort is underway to find a suitable alternatives for cooling application. Solar thermoelectric refrigerator is a special type of refrigerator which is environmental friendly and utilizes solar energy instead of conventional electrical energy to power the thermoelectric module is a promising alternatives compared to

conventional refrigerator. A solar assisted thermoelectric module (TEM) has zero emissions and is capable of producing a temperature difference when provided with electricity. Thermoelectric module technology pumps a heat in a specific direction after passing a current through it which results with hot and cold sides. As the electricity is provided from a clean source like the solar energy, it is 100% environmental friendly refrigerator [2].

The developing history of thermoelectric refrigerator can be found in many scientific papers [3-7]. Sofrata [8] conducted an experiment to improve the performance of the thermoelectric refrigerator by developing effective methods to reject the heat from the hot side of the thermoelectric module. Dai, et. al [9] designed a portable thermoelectric refrigerator driven by solar cells which has a COP of 0.23. An experimental investigation was conducted showing a reduction in the refrigeration temperature from 27°C to 5°C in 44 minutes and the coefficient of performance of the system was calculated and found to be 0.16 [10]. Despite the promises of reducing environmental issue and utilize the free solar energy, certain problems still exist in the new cooling technique, for example, the lower COP which limits its practical implementation.

* Corresponding author. Tel.: +(971) 65053908

Fax: +(971) 65585191; E-mail: srahman@sharjah.ac.ae

© 2017 International Association for Sharing Knowledge and Sustainability

DOI: 10.5383/ijtee.14.01.005

The main challenge of this research is to propose a suitable thermoelectric refrigerator for cooling application as well as to improve its coefficient of performance (COP) which indicates the efficiency of the system. The proposed system is powered by free energy (PV module) and a hot chamber is added to use the full potential of the TEM. Therefore, no additional electricity is needed from any external source. Also the system can be used for both simultaneous cooling and heating application with higher system efficiency. An economic analysis is carried out to study the viability of this novel technique.

2. Experimental Apparatus

A schematic diagram of a portable solar thermoelectric refrigerator, which mainly consists of a PV module, charge controller, storage battery, DC-DC converter and thermoelectric refrigerator, is shown in Figure 1. The PV module receives solar energy at daytime and converts it into electric power supplied to the thermoelectric refrigerator. The storage battery is important in storing the excess energy produced by the PV module while it is

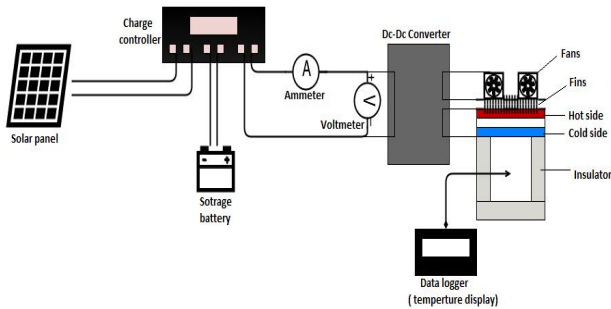

Fig. 1: A schematic diagram shows the connection of all main components of the refrigerator

powering the system. Besides, it can also work as power supply if the PV module is not producing sufficient power, for example in a rainy or a cloudy day. The charge controller plays a role in controlling the amount of power stored in the battery, and finally the DC-DC converter is used to supply the required voltage to the refrigerator after converting the output voltage of the PV module (12V) into the supply voltage (5V). The thermoelectric refrigerator consists of thermoelectric modules (TEM), each of them consists of two sides: the cold side is fixed inside the refrigerator and the hot side is attached with a well-insulated hot chamber for heating application. A pinned type heat sink is attached to the hot side of each TEM to enhance the heat transfer. In order to cool the hot side more efficiently, small fans were added to cover the whole area of the fins. Based on literature survey[11], the refrigerator space temperature was selected of about 12°C which is good for preservation of any type of fruits and vegetables and the hot chamber temperature was about 45°C for any heating application.

The chamber is made of an aluminum sheet (0.3 cm thickness) with a dimension of 6.8 x 6.8 x 15 cm. This aluminum box is well-insulated using thermo-cool insulated material with a thickness of 2 cm to protect heat transfer from the high ambient temperature to the chamber which usually affects the TEMs performance.

Figure 2 shows the final design of the prototype thermoelectric refrigerator. It can be seen from the figure that the PV module fixed to the outer aluminum box which has all the main

components inside it: battery, DC-DC converter, charge controller and the refrigerator cold chamber. It also shows that the thermoelectric modules were fixed on one side of the cold chamber that were attached to fins and fans to enhance heat

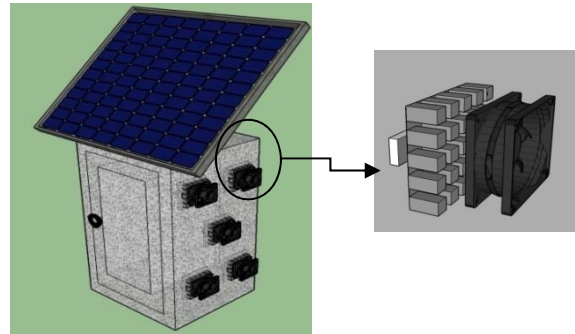

Fig. 2: Final design of solar assisted thermoelectric refrigerator

transfer from the hot side to the chamber. T-type copper-constantan thermocouples (Omega, USA) were used to measure the temperature at different location of the cold



Fig. 3: Front side of the aluminum box

chamber as well as in hot chamber. Thermocouples were inserted at different location where necessary. Temperatures were recorded using a data logger. Figure 3 shows the front side of the aluminum box that has a door to keep all the components safe inside. Also, the refrigerator should be shaded since the entire cooling load calculations were done at shaded conditions

3. Project Design

3.1 Cooling Load

Usually in a refrigerator the chamber temperature for the preservation of vegetables and fruits is between 10°C to 15°C. Based on this reference, target temperature inside the cooling chamber is chosen about 12°C from an average peak ambient temperature which is about 45°C based on UAE metrological condition. A computer program was developed using matlab code for the selection of suitable insulating material and to determine the cooling load for sizing the system component. The cooling load model is briefly described as follows:

$$Q_{\text{cooling-Load}} = U A (T_i - T_a) + Q_{\text{sensible}}$$

$$U = \Sigma h$$

$$h_{c,i-a} = \frac{Nu \cdot k}{L}$$

where U is the overall heat transfer coefficient; A area of the cooling space; h is the heat transfer coefficient; $h_{c,i-a}$ convection coefficient between insulation and ambient; T_i and T_a is the chamber and the ambient temperature, respectively; Nu is the nusselt number and k is the thermal conductivity.

Based on literature, 15% safety factor was considered as an additional load and calculated the final cooling load that needs to be removed by the thermoelectric module. Considering all the factors, the total cooling load for the cooling chamber was about 6.7 W.

3.2. Thermoelectric Module

Thermoelectric module is an electrical component that can work as a heat pump when a voltage difference is applied between its plates. This mode is called the Peltier effect which uses electrical energy to pump the heat from one side to the other. A specific thermoelectric module TE1-12706 was chosen to remove the required amount of heat with a dimension of (30 mm x 5 mm). From the specification sheet of the TEM, graphs were used to get three main design parameter for each module which are voltage (V), current (I) and wasted heat (Q) of about 0.8V, 1.5A, 1.89 W, respectively. To address the cooling load 6 thermoelectric module (TEM) were used in the prototype. In selection of number of module, usually more number of module offer better performance, however availability of space to fix up the modules is also needed to be considered. Considering all the issues, 6 modules were selected to get better performance. All 6 modules were connected in series and placed on one side of the refrigeration to get the cooling and heating effect simultaneously. The cold side of the module was set inside the refrigerator space and the hot side was attached with a hot chamber. The heat sink was attached to the hot side of the thermoelectric module to release heat more effectively into the hot chamber. The TEM used consists of two wires, the red and the black wires were connected to the positive and the negative power supply, respectively. Thermocouples were used to measure the temperatures of each side of the TEM, and were connected to a data logger to record the data round the clock. Thermocouple were added at different locations inside the cold chamber for example, at the surface of the TEM, close to it and at the middle of the box, to be able to study the temperature gradient and the behavior of the free convection currents.

3.3. Fin and Fan Design

Pinned fins were used to cool the TEM since they provide better performance than the flat and the finned type heat sink. Depending on the dimension of the TEM, the type of heat sink BDN12-5CB\A01 with a dimension of 30.73 mm x 30.73 mm was found the best option from the fin selection specification sheet. Six fins were attached to each TEM to enhance and increase the heat transfer rate from its hot surface. Based on design criteria, to maintain the temperature at about 25°C on hot side of the module and 40°C in hot chamber, the total convection heat transfer was found to be 3.06W. Design and selection of fan were performed to meet the said heating load. From the specification sheet the thermal resistance of the fin for a force convection is 5.2 C/W when the air speed is about

2.033 m/s. Based on the above specification the heat removed by the fin is about 3.846W which is closed to the value of the said convection heat load. Therefore, design criteria of fan are to satisfy the air speed 2.033 m/s. Using different fan model specification sheet 2 fans (Model: DA02010B**H) with 2.033 m/s air speed, operating at a 12 VDC voltage and 0.14 A current with a dimension of (40x40x10 mm) were used to cover the whole area of the 6 TEM to cool it down.

3.4. PV Module and Storage System

The system was designed based on fully renewable source round the year powered by the PV modules along with storage system by using batteries. A storage system is needed to accumulate excess energy created by PV system at day time and meet the demand in a cloudy day, rainy day and at night when the solar energy is not available. The size of the photovoltaic array was determined to fulfill the demand of total load for TEM and fan. During sizing of PV array the availability of solar insulation, tilt angle, orientation of the array and the characteristics of the photovoltaic modules were considered. Furthermore, the PV array was sized to meet the average daily demand for electricity during the worst insulation month of the year, which is December in Sharjah, United state of Arab Emirates. The PV array was placed towards south facing and tilted at an angle of 25.35 degrees from the horizontal in order to maximize the insulation received during December.

Power consumed by the 6 modules and 2 fans were about 36 Wh and 16.8 Wh, respectively. Based on total demand (36Wh +16.8Wh=) 52.8 Wh, the PV module and storage system were determine. A PV module with 15 Watts and 12 V and a battery with 7 Ah and 12 V was estimated to fulfil the total demand around the year in any circumstances.

3.5. Charge Controller and DC-DC Convertor Sizing

A solar regulator or charge controller is a small box consisting of solid state circuitry that is placed between a solar panel and a battery. Its function is to regulate the amount of charge coming from the panel that flows into the deep cycle battery bank in order to avoid the batteries being overcharged. A regulator can also provide a direct connection to appliances, while continuing to recharge the battery; i.e. can run appliances directly from it, bypassing the battery bank; but the batteries will continue to be charged. An appropriate charge controller with 10A and 12V was selected by calculating the charge input current (minimum controller input current) 1.675Amp and controller load current (minimum controller input current) 0.58 amp.

DC-DC converter was used with multiple output channels to provide protection from (a) over current, noise, isolation between the source side and the load side (b) step-down the voltage as required and (c) supply more than one load in a manner of connection and make sure the two loads are independently operated. A 25 Watts DC-DC converter (Model no: PS25-1212) was selected after comparing several brand of convertor.

4. Performance Analysis

4.1 Effect of Fin on Hot and Cold Side Temperature of TEM.

Figure 4&5 shows the effect of fin on hot and cold side temperature of TEM at various current inputs. It was observed that the cold side temperature without fin was increasing with the increases of current reaching at 25°C as shown in Figure 4, which is very high for a refrigerator. However, with fin the cold temperature decreases upto 5°C with the increases of current increases at the same level.

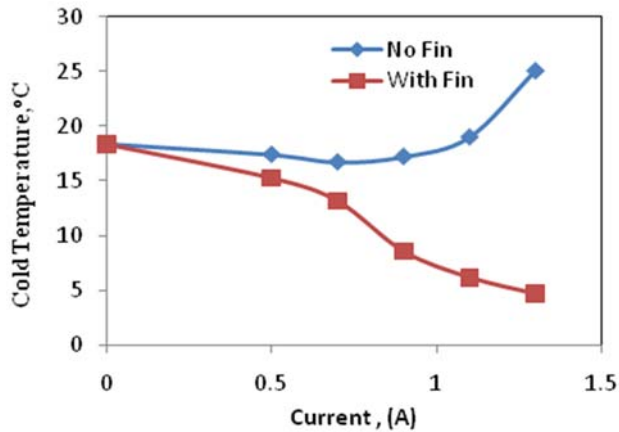

Fig. 4: Variation of cold side temperature with current in TEM with and without fin

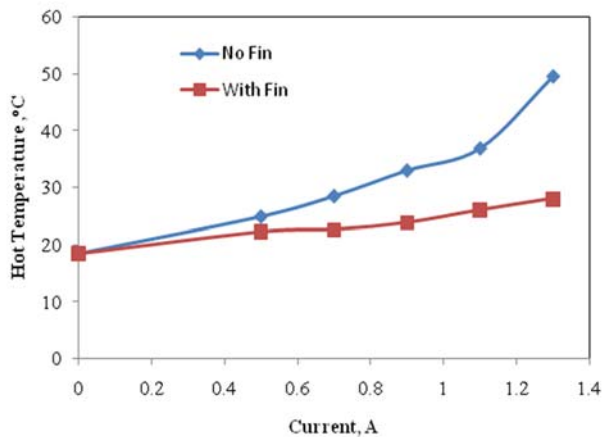

Fig. 5: Variation of hot side temperature with current in TEM with and without fin.

Figure 5 shows that the hot side of TEM temperature reaches 50°C without a fin. Performance of the TEM decreases when the hot side reaches a high temperature. While with fin, temperature varies between 20°C to 25°C which shows the promising effect of fin for better performance of TEM. At 1.3 a current input, the temperature difference on cold and hot side with and without fin was about 21°C and 22°C, respectively. It can be attributed to the fact that adding of fin increases the heat transfer area and hence increases the heat transfer rate. As a result temperature of both cold and hot side is decreases.

4.2 Effect of Input Current on TEM Performance at Controlled Environment Inside Laboratory

Figure 6 & 7 shows the variation of temperature with time at cold side (T_s), hot side (T_h) of TEM and also in middle of the refrigerator chamber (T_m) at 1 A and 1.5 A supply current, respectively. These experiments were conducted at indoor condition inside the laboratory at about 24°C to investigate the performance of TEM at various current input from power source. Figure 6 shows that the hot and cold surface of TEM reaches at about 21°C and 10°C, respectively from an initial temperature of 24°C and in the middle of the chamber reaches about 15°C within about 1.5 minutes and remain almost stable during the course of experiment. This results indicates an excellent behavior of TEM mainly sharp drop of temperature and to maintain the temperature at stable condition which is an essential requirement for the operation of the refrigerator chamber.

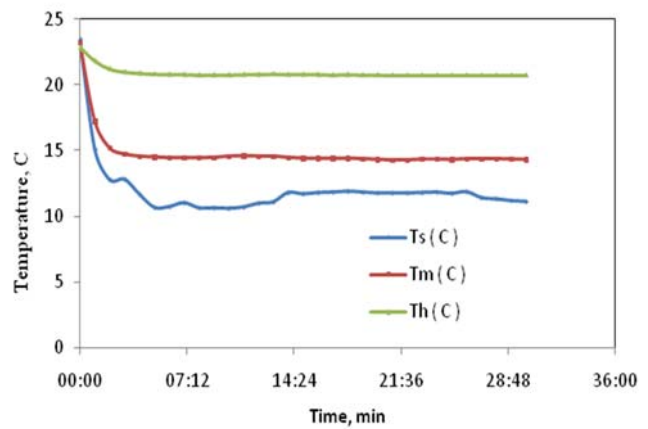

Fig. 6: Variation of temperature at cold side of TEM (T_s), inside the cold chamber (T_m) and hot side of TEM (T_h) with time at 1A supply current

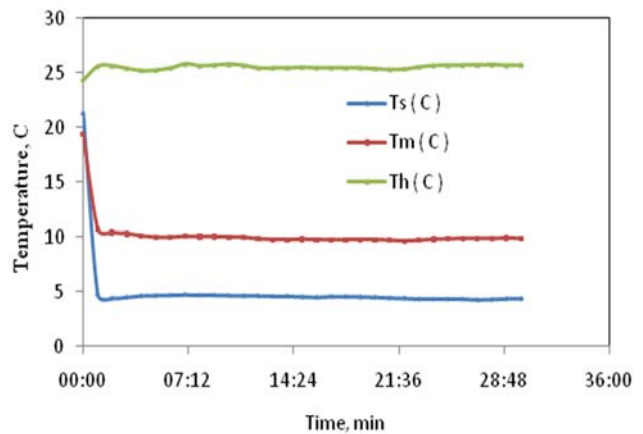

Fig. 7: Variation of temperature at cold side of TEM (T_s), inside the cold chamber (T_m) and hot side of TEM (T_h) with time at 1.5 A supply current

Figure 7 shows the behavior of the refrigerator as it works with the designed current at 1.5A. The system succeeded to reach temperature close to 10°C in the middle of the box and 4°C at the cold side of TEM surface. The temperature in the middle of the box remained constant with the time as the thermal conductivity of the air is very low and there is nothing inside the chamber to enhance the heat transfer. Temperature

difference between the hot and cold side of TEM with ambient was found to be about 4.7°C and 16.7°C, respectively. Results indicates that with the current supply to the system, increases the temperature difference between the ambient and the both end (hot and cold) of TEM as well as the cold chamber temperature. As expected and observed that the variation of the cold side temperature was higher than the variation of the hot side temperature with the increase of input current. These results proved that the TEM responded very well different input current which is an important and essential behavior of TEM for smooth operation of the whole system. To get a real flavor of cooling performance of the prototype refrigerator chamber, a small tube filled with water was kept inside the refrigerator and it took 2 hours to reduce the water temperature from 24°C to 17°C, which indicates a promising performance of the proposed designed refrigerator.

4.3. Performance Analysis of the Prototype Refrigerator Using PV as well as in Actual Ambient Condition

Figure 8. shows the result of variation of temperature at both end of TEM and in the middle of cold chamber when the refrigerator was powered by the PV module during daytime at 2 PM. Recorded ambient temperature was about 35°C and solar radiation of 90 kWh/m². The hot and cold side temperature of thermoelectric was about 40°C and 10°C, respectively while the temperature inside the refrigerator stabled at 19°C within 2-3 minute. It is important to note that all temperature variation reached in stable condition within a very short interval of about 2-3 minutes and remain constant during the course of the experiment. Temperature inside the cold chamber is bit higher about 9°C than the target temperature. Closer target temperature may be achieved by using proper insulation or at higher operating input current to TEM. Figure 8 also shows a remarkable temperature difference between the hot and cold side of the TEM with ambient condition was about 4.4°C and 24.5°C, respectively within a very short period of time. Results revealed an excellent performance of the proposed solar

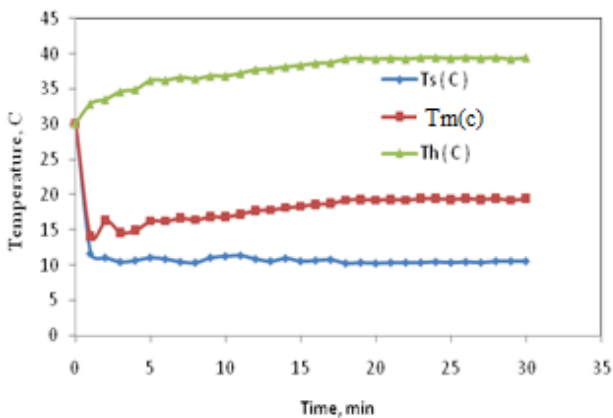

Fig. 8: Variation of temperature at cold side of TEM (Ts), inside the cold chamber (Tm) and hot side of TEM (Th) with time at 2PM powered by PV cell

thermoelectric refrigerator in a real life operating condition. Figure 9 shows the performance of refrigerator during night at 8PM. The system was powered by the battery due to unavailability of solar energy, as the experiment conducted at night. Temperature at the middle of the cold chamber and on

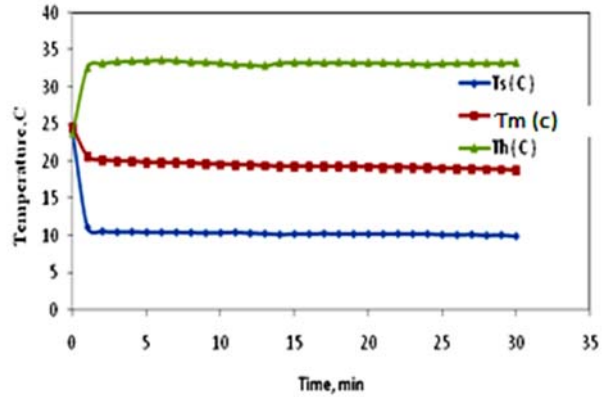

Fig. 9: Variation of temperature at cold side of TEM (Ts), inside the cold chamber (Tm) and hot side of TEM (Th) with time at 8PM powered by PV cell

the cold surface of the TEM was approximately 10°C and 19°C, respectively. While the hot side temperature of TEM was about 33°C. Comparing the results between Figures 8 and 9, it is observed that the performance of the refrigerator is almost same both at day and night as it reaches approximately the same temperature in the middle of the chamber as well as in cold side of TEM, while, the hot side temperature was bit higher at day time compare at night because of higher ambient temperature at day time. From the above investigation it can be concluded that the proposed solar thermoelectric refrigerator is suitable to run efficiently round the clock.

4.4. The System Coefficient of Performance (COP)

Coefficient of performance represents a ratio of heating or cooling provided to electrical energy consumed.

$$COP = Q_{cooling\ load} / Q_{PV}$$

MATLAB code was used to measure the cooling load removed by the six TEMs and it was found to be 4.8137 W, and the energy supplied to the system from the PV was about 14.4W. Based on this cooling load COP was about 0.334.

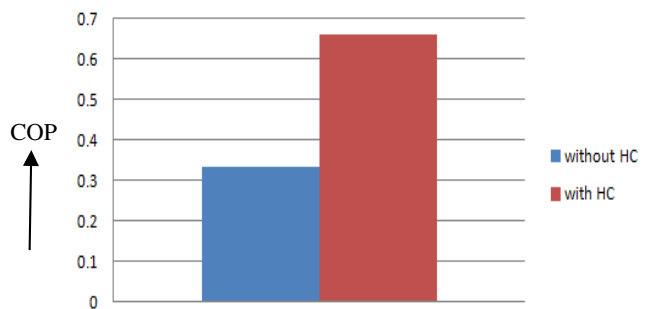

Fig. 10: Comparison between the COP of the of the refrigerator with and without the hot chamber

The hot side of the solar refrigerator was designed at a hot chamber, which was closed and insulated from all the sides. Therefore, the heat released from the hot side of the TEM can be used for heating purposes. But during experiments, it was noticed that when the hot side was closed there was no air circulation to get rid of the excess heat produced by the TEMs, so the hot side temperature increases and affects the performance of the TEMs at the cold side. This is because of

small dimension of the hot chamber; however in actual application chamber size will large be enough and wouldn't affect the performance of the TEM.

On the other hand, adding a hot chamber increases the COP approximately the double of the initial COP which was calculated based on only cooling load. This is because the heat remove from the cold side is equal to the heat release at the hot side, so the new COP after considering a hot chamber is about 0.66. Figure 10 shows the comparison of COP of the refrigerator with and without the hot chamber.

5. Cost Analysis

The cost of the system plays an important role on evaluating the project. The cost of the prototype has been calculated. The total cost of the prototype including all its components is around 3000 AED. The detailed cost analysis is presented in Table 1.

Table 1: Total cost of the prototype

	Components	Quantity	Cost(AED)
1	TEM	6	480
2	Fins	6	18
3	Fans	2	15
4	PV module	1	120
5	Battery	1	60
6	Charge controller	1	80
7	DC-DC convertor	1	160
8	Materials and main structure fees	-	2000
Total cost			2933

5.1. Prototype Scaling

The prototype was scale up to the size of the domestic refrigerator in the houses.

Table 2. Cost of scale up prototype

	Components	Quantity	Cost(AED)
1	TEM	4	470
2	Heat sink (Fins + fans)	4	400
4	PV module	1	1064
5	Battery	1	800
6	Charge controller	1	100
7	DC-DC convertor	1	250
8	Materials and main structure fees	-	5000
Total cost			8084

A domestic refrigerator (Model: RT50H6670SL) with the dimension of 1785mm x 770mm x 770mm was chosen to do a comparison interms of performance and cost with respect to the scale up prototype of thermoelectric refrigerator. Table 2 shows the total cost of scale up prototype.

5.2 Comparison Between Thermoelectric Refrigerator and Domestic Refrigerator

The initial cost of the scale up thermoelectric refrigerator with 1780 mm x 770 mm size is about 8084 AED as shown in Table 2. The target temperature in the refrigerator was 12°C and powered by solar PV panels. The lifetime of the fridge is 40 years as the thermoelectric can work upto 350,000 hours which is equivalent to 40 years.

The domestic refrigerator model no: RH77H90507F has been chosen for comparison. The cost of domestic refrigerator is about AED12,000 and powered by the electricity from the grid. The lifetime is about 15 years.

In comparison, the initial cost of the thermoelectric refrigerator is less than the initial cost of the traditional refrigerator. Also thermoelectric module will be powered from free source, and hence there will not be any additional cost for 40 year, while the traditional refrigerator has monthly payment of electricity bill. Furthermore, the life time of the thermoelectric refrigerator is longer than the traditional one. However, the COP of the TEM refrigerator is lower compare to the traditional refrigerator. This limitation can be compromised comparing with other advantages of TEM refrigerator as mention above. The detailed comparison is shown in Table 3.

Table 3. Comparison between thermoelectric refrigerator and domestic refrigerator

Refrigerator type	Initial cost (AED)	Powered source	Target temperature	Life time
Thermoelectric	8084	PV	12°C	40 years
Traditional refrigerator (RH77H90507F)	12,000	Grid	12°C	15 years

6. Conclusion

In this research, a new portable thermoelectric cooling system was designed, fabricated and tested based on the principle of thermoelectric module for both cooling and heating application. A detailed design methodology was presented which can be used as an important tool for commercial application. In order to utilize renewable energy, solar energy was integrated to power the thermoelectric module in order to drive the refrigerator. In design storage battery was included to run the system for round the clock operation as well as in cloudy and rainy day. Experimental results illustrated that the proposed system achieved and maintained the target temperature inside the cooling chamber during day time as well as at night. System also provided a suitable temperature for heating application. Cost analysis demonstrated that proposed system is economically viable as compare to traditional refrigerator. Coefficient of performance was obtained about 0.66, which is bit lower compare to conventional refrigerator. However, the solar thermoelectric refrigerator is environmentally friendly that does not produce chlorofluorocarbon (CFC) as in the conventional refrigerators, which contributes to ozone depletion in the upper atmosphere. In addition, it is small in size and has no noise and vibration. Also, the rejected heat is negligible compared to the heat rejected from the conventional refrigerators. Hence, the solar thermoelectric refrigerator would be less harmful to the environment.

Acknowledgments

The authors would like to thank University of Sharjah for providing the financial support for the successful completion of this project.

References

- [1] M. J. Calm. Emissions and environmental impacts from air-conditioning and refrigeration systems. *International Journal of Refrigeration* 2010; 25(3):293-305.
- [2] H. Xi, L. Luo, G. Fraisse. Development and applications of solar-based thermoelectric technology. *Renewable and Sustainable Energy Review* 2007; 11: 923-36.
- [3] F. D. Salvo. Thermoelectric cooling and power generation. *Science* 1999; 285: 703-706.
- [4] V.C. Mei, F.C. Chen, B. Mathiprakasham, P. Heenan. Study of solar-assisted thermoelectric for automobile air-conditioning. *Journal of Solar Energy Engineering Transaction ASME* 1993; 115(4): 200-205.
- [5] S.B. Riffat, M.A. Xiaoli. Thermoelectric: A review of present and potential applications. *Applied Thermal engineering* 2003; 23: 913-935.
- [6] S.B. Riffat, Q. Guoquan, Comparative investigation of thermoelectric air-conditioners versus vapour compression and absorption air-conditioners. *Applied Thermal Engineering* 2004; 24: 1979-1993.
- [7] P.K. Bansal, A. Martin. A comparative study of vapour compression, thermoelectric and absorption refrigerators. *International Journal of Energy Review* 2000; 24 (2): 93-107.
- [8] H. Sofrata, Heat rejection alternatives for thermoelectric refrigerator. *Energy Conversion and Management* 1999; 37(3): 269-280.
- [9] V.J Dai, R.Z. Wang, L. Ni. Experimental investigation on a thermoelectric refrigerator driven by solar cells. *Renewable Energy* 2003; 28: 949-99.
- [10] S. A. Abdul-Wahab, A. Elkamel, A. M. Al-Damkhi, A, Is'haq, A, Al-Habsi, S, Hilal, K, Abdulaziz, A, Al-Battashi, R, Ali, A, Al-Tamimi, H, Khamis, A, Al-Mamari, U, Muhammad. Design and experimental investigation of portable solar thermoelectric Refrigerator. *Renewable Energy* 2009, 34: 30-34.
- [11] Roy J. Dossat, *Principles of Refrigeration* (4th Edition), John Wiley, 1997.