

Development of Intermediate Pressure Correlation for the Half-Effect Absorption Cooling Chiller

Rabah GOMRI *

*Laboratory of «Génie Climatique», Faculty of Engineering, Department of «Génie Climatique»,
University of Constantine, 25000 Constantine, Algeria*

Abstract

This paper investigates the two stage half-effect absorption system. The main components of this system are: the condenser, the evaporator, the two generators (low pressure generator and high pressure generator) and the two absorbers (low pressure absorber and high pressure absorber). The evaporator and low pressure absorber operate at low pressure (evaporation pressure P_{ev}). The low generator pressure and high absorber pressure operate at intermediate pressure (P_i) and the high generator pressure and the condenser operate at high pressure (condenser pressure, P_{cd}). For a given set of generators, evaporator, condenser and absorbers temperatures, the intermediate pressure (P_i) must be optimized to get a maximum coefficient of performance 'COP' and exergy efficiency of the system.

This paper enables us to obtain immediately the intermediate pressure, P_i through a newly developed correlation. This correlation is valid for a commonly used chilled water temperature ($12^\circ\text{C}/7^\circ\text{C}$) when the evaporation temperature is maintained at 4°C , condenser and absorber temperatures are varied from 28°C to 38°C and generator temperature is varied from 40°C to 80°C . It is found that the maximum COP values of the half-effect cooling systems are in the range of 0.41–0.43 and the maximum exergetic efficiency for half-effect cooling systems are in the range of 14.7%–22.6%.

Keywords: *Absorption; Cooling; Half-effect; Intermediate Pressure; Correlation; Efficiencies.*

1. Introduction

Refrigeration and air conditioning systems have a major impact on energy demand with roughly 30% of total energy consumption in the world. With fossil fuels fast depleting, it is imperative to look for refrigeration systems that require less high-grade energy for their operation. In this context, chilled water production through absorption cycles has been traditionally considered one of the most desirable applications for thermal heat source. In the same way the ability to use low grade heat, such solar thermal systems, waste heat, geothermal sources, ect., is a strong reason for using absorption cooling systems. Absorption cooling systems have become increasingly popular in recent years from the viewpoints of energy and environment. They work on heat-operated cycle with environment friendly working fluids. The basic absorption cycle employs two fluids, the absorbate or refrigerant, and the absorbent. The most commonly fluids are water as the refrigerant and lithium bromide as the absorbent ($\text{H}_2\text{O-LiBr}$ solution).

The principle of the half-effect cycle is that it has two lifts. The term lift is used to represent a concentration difference between

the generator and absorber. This concentration difference is what drives or gives the potential for mass to flow into the absorber. With the single effect there is only one lift.

Many researchers have reported works on half-effect cycles. Ma and Deng [1] have reported preliminary results of an experimental investigation on a 6 kW vapour absorption system working on half-effect cycle with $\text{H}_2\text{O-LiBr}$ as the working fluids. With hot water temperature requirement of around 85°C , a chilled water temperature of 7°C has been reached in their experiment. Sumathy et al. [2] have tested solar cooling and heating system with a 100 kW half effect absorption chiller working on the same cycle. The system has been used successfully with generation temperatures in the range of $65\text{--}75^\circ\text{C}$ to achieve a chilled water temperature of 9°C . Arivazhagan et al. [3] presented a simulation studies conducted on a half effect vapour absorption cycle using R134a-DMAC as the refrigerant-absorbent pair with low temperature heat sources for cold storage applications. Arivazhagan et al. [4] presented experimental studies on the performance of a half effect vapour absorption cooling system. The prototype was designed for 1 kW cooling capacity using HFC based working fluids (R134a as refrigerant and DMAC as absorbent).

* Corresponding author. Tel.: +213664317045

E-mail: rabahgomri@yahoo.fr

© 2010 International Association for Sharing Knowledge and Sustainability

DOI: 10.5383/ijtee.02.01.005

Gomri [5] presented the simulation results and an overview of the performance of low capacity two stage half-effect absorption cooling system (10kW), suitable for residential and small building applications. The primary heat source is solar energy supplied from flat plate collectors. The complete system (solar collectors-absorption cooling system) was simulated using a developed software program. The energy and exergy analysis is carried out for each component of the system. All exergy destroyed that exist in this solar cooling system are calculated. Critical temperatures which are the minimum allowable hot water inlet temperatures are determined. This system has shown promising characteristics.

In this paper the energy and exergy analysis is carried out for each component of the system. All exergy that exits in this system are calculated. The coefficient of performance and the exergetic efficiency of the system are estimated. The effect of generator temperature, absorber temperature and condenser temperature were analysed for a commonly used chilled water temperature (12°C/7°C).

2. System description

The half-effect absorption cooling system as shown in figure 1 consists of condenser, evaporator, two generators, two absorbers, two pumps, two solution heat exchangers, two solution reducing valves and a refrigerant expansion valve. In the system operation, the evaporator and low pressure absorber operate at low pressure (evaporation pressure P_{ev}). The low generator pressure and high absorber pressure operate at intermediate pressure (P_i) and the high generator pressure and the condenser operate at high pressure (condenser pressure, P_{cd}). Both generators (LPG and HPG) can be supplied with heat at the same temperature.

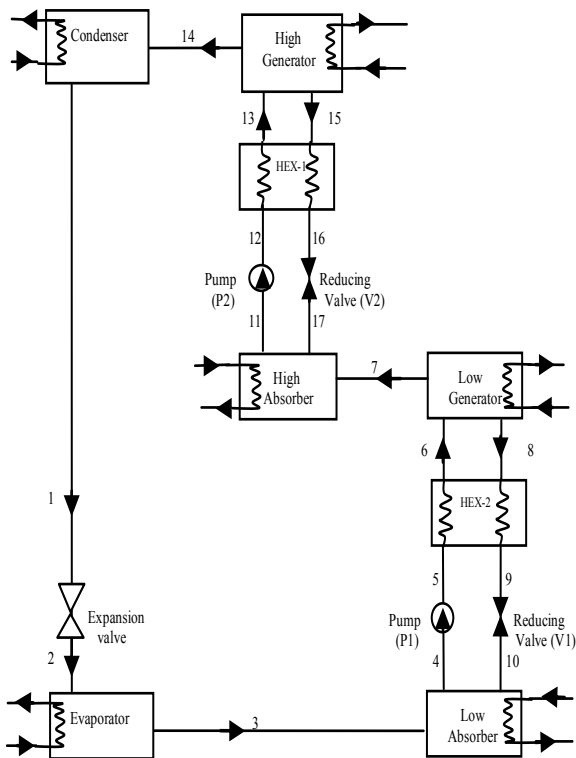

Fig. 1. The schematic illustration of half-effect absorption cooling system

The refrigerant vapour from the evaporator is absorbed by the strong solution in the low absorber. The weak solution from the low absorber is pumped to the low generator through the low solution heat exchanger. The strong solution in the low generator is returned to the low absorber through the low solution heat exchanger. The refrigerant vapour from the low generator is absorbed by the strong solution in the high absorber. The weak solution from the high absorber is pumped to the high generator through the high solution heat exchanger. The strong solution in the high generator is returned to the high absorber through the high solution heat exchanger. In both heat exchangers, the weak solution from the absorber is heated by the strong solution from the generator. The refrigerant is boiled out of the solution in the high generator and circulated to the condenser. The liquid refrigerant from the condenser is returned to the evaporator through an expansion valve.

3. Mass, energy and exergy analysis

For the thermodynamic analysis of the absorption systems the principles of mass conservation, first and second law of thermodynamics are applied to each component of the system.

3.1 Mass conservation

Mass conservation includes the mass balance of total mass and each material of the solution. The governing equations of mass and type of material conservation for a steady state and steady flow system are:

$$\sum m_i - \sum m_o = 0 \tag{1}$$

$$\sum m_i \cdot x_i - \sum m_o \cdot x_o = 0 \tag{2}$$

Where m is the mass flow rate and x is de mass fraction of Libr in the solution. The mass fraction of the mixture at different points of the system (figure 1) is calculated using the corresponding temperature and pressure data.

The mass flow rate of refrigerant is obtained by energy balance at evaporator and is given as follows,

$$m_3 = \frac{Q_{ev}}{(h_2 - h_3)} \tag{3}$$

3.2 Energy analysis

The first law of thermodynamics yields the energy balance of each component of the absorption system as follows:

$$\left(\sum m_i \cdot h_i - \sum m_o \cdot h_o\right) + \left(\sum Q_i - \sum Q_o\right) + W = 0 \tag{4}$$

The coefficient of performance of the absorption refrigeration is obtained by :

$$COP = \frac{Q_{ev}}{(Q_{gH} + Q_{gL} + W_{p1} + W_{p2})} \tag{5}$$

3.3. Exergy analysis

Exergy analysis is the combination of the first and second law of thermodynamics and is defined as the maximum amount of work, which can be produced by a stream or system as it is brought into equilibrium with a reference environment and can be thought of as a measure of the usefulness or quality of energy [6]. According to Bejan et al. [7] the exergetic balance

applied to a fixed control volume is given by the following equation:

$$Ex_d = \left(\sum_i m_i \cdot ex_i \right)_{in} - \left(\sum_i m_i \cdot ex_i \right)_{out} - E_{heat_j} - W \quad (6)$$

Where Ex_d is rate of exergy destruction. E_{heat} is the net exergy transfer by heat at temperature T_j which is given by

$$E_{heat} = \sum_j \left(1 - \frac{T_0}{T_j} \right) \cdot Q_j \quad (7)$$

W is the mechanical work transfer to or from the system. The specific exergy of flow is:

$$ex = (h - h_0) - T_0 (s - s_0) \quad (8)$$

m is the mass flow rate of the fluid stream, h is the enthalpy, s the entropy and the subscripts 0 stands for the restricted dead state

The exergetic efficiency (rational efficiency) can be calculated as the ratio between the net exergy produced by the evaporator (exergy desired output) and the input exergy to the generator (exergy used) plus the mechanical work of the solution pumps:

$$\eta_{exergy} = \frac{Q_{ev} \cdot \left(1 - \frac{T_0}{T_b} \right)}{\left[(Q_{gH} + Q_{gL}) \left(1 - \frac{T_0}{T_h} \right) + (W_{p1} + W_{p2}) \right]} \quad (9)$$

T_b and T_h are the mean temperature of the cold source (in the evaporator) and the hot source (in the generator) respectively.

The systems are simulated assuming the following conditions:

- The analysis is made under steady conditions.
- The refrigerant (water) at the outlet of the condenser is saturated liquid.
- The refrigerant (water) at the outlet of the evaporator is saturated vapour.
- The Lithium bromide solution at the absorber outlet is a strong solution and it is at the absorber temperature
- The outlet temperatures from the absorber and from generators correspond to equilibrium conditions of the mixing and separation respectively.
- Pressure losses in the pipelines and all heat exchangers are negligible.
- Heat exchange between the system and surroundings, other than in that prescribed by heat transfer at the HPG, evaporator, condenser and absorber, does not occur
- The reference environmental state for the system is water at an environment temperature T_0 of 25°C and 1 atmospheric pressure (P_0)
- The system produce chilled water, and generator is driven by hot water.
- The system rejects heat to cooling water at the condenser and absorbers.
- Both generators are supplied with heat at the same temperature.
- The refrigerant flow rate leaving the low temperature generator is equal to the refrigerant flow rate leaving the high temperature generator.

Simulations are carried out for a constant refrigeration capacity $Q_{ev}=300$ KW, Pump efficiency $\eta_p=85\%$, Heat exchangers effectiveness $\epsilon_1=\epsilon_{II}=70\%$, condensation temperature is equal to the absorber temperature $T_{cd}=T_{ab}$. Condensation temperature is varied in the following range: $T_{cd}=28^\circ\text{C}$ to 38°C . The outlet temperature of cooling water has been assumed at $T_{cd}-3$ and the inlet temperature of cooling water has been assumed at $T_{cd}-8$. Evaporation temperature is maintained at $T_{ev}=4^\circ\text{C}$. The outlet temperature of chilled water has been assumed at $T_{ev}+3$ and the inlet temperature of chilled water has been assumed at $T_{ev}+8$. Generation temperature “ T_g ” is varied from 40°C to 80°C . The outlet temperature of hot water has been assumed at T_g+8 and the inlet temperature of hot water has been assumed at T_g+18 .

In this analysis, the thermal-physical properties of the working fluids have to be known as analytic functions. A set of computationally efficient formulations of thermodynamic properties of lithium bromide/water solution and liquid water developed by Patek and Klomfar [8] are used in this work. The equations for the thermal properties of steam are obtained from correlation provided by Patek and Klomfar [9].

4. Results and discussion

A computer program, which is written in FORTRAN was developed for thermodynamic analysis. The program was based on the energy balances, thermodynamic properties for each reference point. The initial conditions are given into the program including the ambient conditions, the component temperatures, pump efficiency, effectiveness of heat exchangers and cooling load. With the given parameters, the thermodynamic properties of the mixture at all reference points in the cycle were calculated. Using thermodynamic properties the COP, thermal loads of the components, exergy destroyed of each component of the system are calculated separately and exergy efficiency of the cooling system are calculated for different working conditions and the change of thermodynamic properties with the other variables of the system.

4.1. Calculation of the intermediate pressure

For a given set of generator, evaporator, condenser and low and high absorber temperature, the intermediate pressure was optimized to get maximum coefficient of performance ‘COP’ and exergy efficiency. Figures 2 and 3 give the variation of COP and the exergy efficiency versus the intermediate pressure for different half-effect generator temperature when the condenser and evaporator temperatures are maintained at 33°C and 4°C respectively.

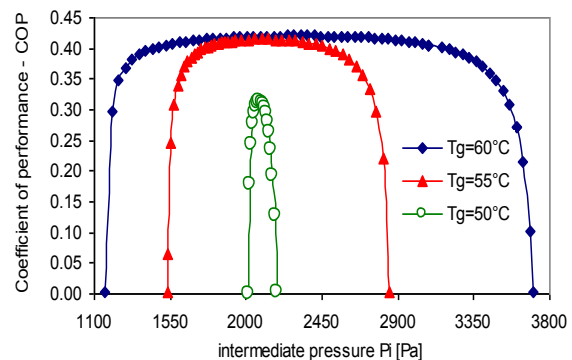

Fig. 2. Coefficient of performance versus the intermediate pressure

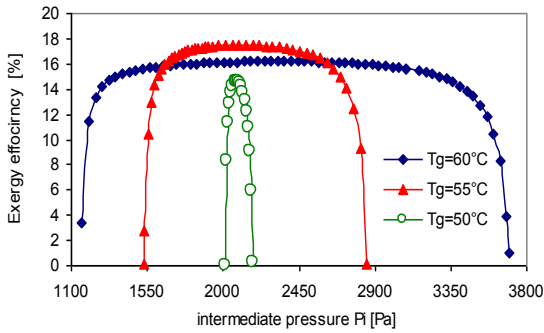

Fig.3. Exergy efficiency versus the intermediate pressure

It can be seen that when $T_{ev}=4^{\circ}\text{C}$ and $T_{cd}=T_{ab}$ and when T_g is varied from 50°C to 60°C by step of 5°C the interval of P_i giving the maximum COP and exergy efficiency increases when T_g increases.

4.2. Development of the intermediate pressure correlation

The values of the intermediate pressure obtained from the simulation model were used in order to develop the following relation (Eq. 10), the least squares method has been used in this case [10-12].

$$P_i = \left(a_1 \cdot e^{a_2 \cdot t_{cd}} \right) t_g^2 + (a_3 \cdot t_{cd} + a_4) t_g + a_5 \cdot t_{cd}^{a_6} \quad (10)$$

Where:

t_{cd} : condenser temperature [$^{\circ}\text{C}$]

t_g : generator temperature [$^{\circ}\text{C}$]

$a_1=3.0917$

$a_2=0.0087$

$a_3=-17.3190$

$a_4=141.2300$

$a_5=6.9464$

$a_6=2.1608$

This correlation is valid for the following parameters:

t_{cd} varying from 28°C to 38°C

t_g : varying from 40°C to 80°C

t_{ev} (evaporator temperature)= 4°C (chilled water : $7^{\circ}\text{C}/12^{\circ}\text{C}$)

This correlation enables us to obtain immediately the optimized intermediate pressure to get maximum coefficient of performance ‘COP’ and exergy efficiency of the half-effect absorption cooling systems.

4.3. First law analysis

The effects of the generator, absorber and condenser temperature on the coefficient of performance are shown in figure 4. The high COP values are obtained at high generator and low condenser temperatures. For a given evaporator, absorber and condenser temperature, there is a minimum generator temperature which corresponds to a maximum COP. In this study and when the condenser temperature is varied from 28°C to 38°C the maximum COP values of half-effect cooling systems are in the range of 0.408–0.435. It should be

noted that the COP initially exhibits significant increase with an increasing generator temperature, and then the slope of the COP curves become almost flat. In other words, increasing the generator temperature higher than a certain value does not provide much improvement for the COP.

4.4. Second law analysis

The variation of exergetic efficiency with generator temperature for single and half-effect cooling systems at different condenser temperatures is shown in figure 5. Exergetic efficiency increase with an increase in the generator temperature up to a certain generator temperature (for a given evaporator, absorber and condenser temperature, there is a minimum generator temperature which corresponds to a maximum exergy efficiency) and then decrease.

In this study and when the evaporation temperature is maintained at 4°C and condenser and absorber temperatures are varied from 28°C to 38°C the maximum exergetic efficiency values of half-effect cooling systems are in the range of 14.7%–22.6%.

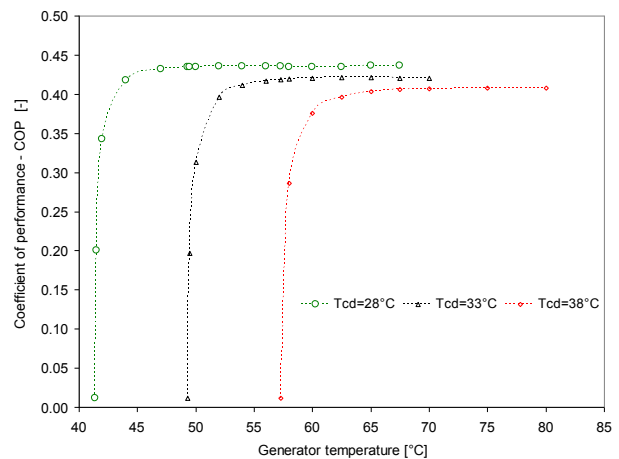

Fig. 4. Coefficient of performance versus generator temperature and condenser temperature (for $t_{ev}=4^{\circ}\text{C}$)

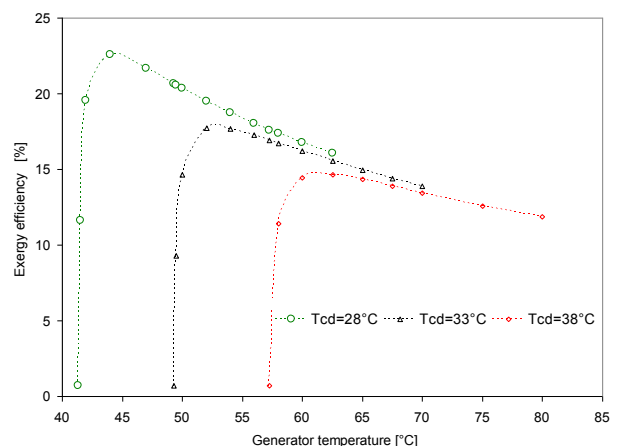

Fig. 5. Exergy efficiency versus generator temperature and condenser temperature (for $t_{ev}=4^{\circ}\text{C}$)

As the efficiencies of the first and second laws are examined here, it is seen that exergetic efficiency increases up to a certain generator temperature (variable with condensation temperature). Furthermore, COP value also increases up to about this temperature. At the higher generator temperatures,

while COP remains approximately constant, exergetic efficiency decreases gradually. The reason for this is that the increase in the generator temperature negatively influences the exergetic efficiency value as seen from Eq. (9). It can be seen that the system experiences better exergetic efficiency at low condenser temperature temperatures within some generator temperature ranges. The exergetic efficiency initially increases and declines continuously as the generator temperature increases.

The variation of total exergy loss with generator temperature for cooling at different condenser temperatures is shown in figure 6. The total exergy loss of the two types of absorption refrigeration systems drops sharply to a minimum value with an increase of generator temperature and then increases further. For each condenser and evaporator temperature there is a generator temperature at which the total exergy loss of the absorption refrigeration systems is minimum which correspond to a maximum value of exergy efficiency.

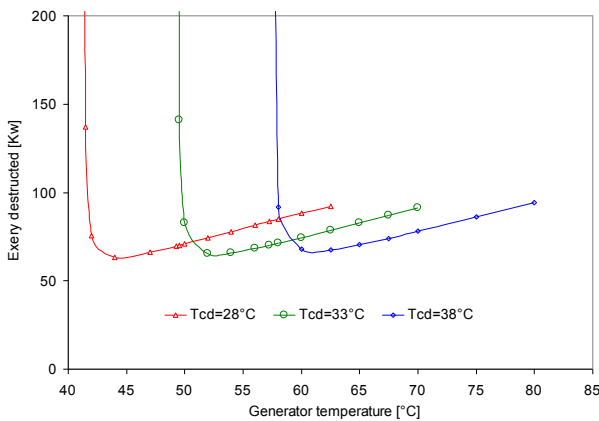

Fig. 6. Exergy destructed versus generator temperature and condenser temperature (for $t_{ev}=4^{\circ}\text{C}$)

3. Conclusion

In this study, the first and the second law of thermodynamics are applied to half-effect absorption refrigeration systems. COP, exergetic efficiency and the exergy loss of each component, the total exergy loss of all components are calculated from the thermodynamic properties of the working fluids at various operating conditions by using the developed mathematical model.

- The results show that COP of the cycle increases with increasing generator, but decreases with increasing condenser temperatures.
- For each condenser and evaporator temperature, there is an optimum generator temperature where the total exergy loss of the single effect and half-effect absorption cooling systems is minimum. At this point the COP and exergetic efficiency of the systems become maximum
- In this study and when the evaporation temperature is maintained at 4°C and condenser and absorber temperatures are varied from 28°C to 38°C the maximum COP values of half-effect refrigeration systems are in the range of 0.408 – 0.435. The maximum exergetic efficiency values of half-effect cooling systems are in the range of 14.7% – 22.6%.

- While the efficiency of the first law increases or remain constant, the efficiency of the second law may decrease.
- The half effect system can function at low generator temperature depending on condenser temperature. Less is the condenser temperature less is the generator temperature giving the maximum COP and exergy efficiency.
- This paper enables us to obtain immediately the intermediate pressure, P_i through a newly developed correlation. This correlation is valid for a commonly used chilled water temperature ($12^{\circ}\text{C}/7^{\circ}\text{C}$) when the evaporation temperature is maintained at 4°C , condenser and absorber temperatures are varied from 28°C to 38°C and generator temperature is varied from 40°C to 80°C .

Nomenclature

COP	Thermal efficiency (coefficient of performance) of the absorption cooling system
Ex	Exergy, kW
ex	specific exergy, kW/kg
h	Enthalpy, kJ/kg
HPG	High pressure generator
LPG	Low pressure generator
m	Mass flow rate of the fluid stream,
Q	Heat (Energy), kW
s	Entropy, kJ/kg.K
T	Temperature, K
W	Mechanical work transfer to or from the system, kW
T	Temperature, K

Greek Symbols

η	Efficiency
ε	Heat exchanger effectiveness

Subscripts

0	Reference value
a	Ambient
ab	absorber
b	Cold source
cd	Condenser
d	Destruction
ev	Evaporator
g	Generator
gH	High pressure generator
gL	Low pressure generator
h	Hot source
j	Heat source number
p	Pump

References

- [1] Ma WB, Deng SM. Theoretical analysis of low temperature hot source driven two stage LiBr-H₂O absorption refrigeration system. *Int. J. of refrigeration* 1996;19(2):141-146.
- [2] Sumathy K, Huang ZC, Li ZF. Solar absorption cooling with low grade heat source - A strategy of development in South China. *Solar Energy* 2000; 72(2):155-165. [http://dx.doi.org/10.1016/S0038-092X\(01\)00098-6](http://dx.doi.org/10.1016/S0038-092X(01)00098-6)
- [3] Arivazhagan S, Murugesan SN, Saravanan R, Renganarayanan S. Simulation studies on R134a-DMAC based half effect absorption cold storage systems. *Energy Conversion and Management* 2005; 46: 1703-1713. <http://dx.doi.org/10.1016/j.enconman.2004.10.006>
- [4] Arivazhagan S, Saravanan R, Renganarayanan S. Experimental studies on HFC based two-stage half effect vapour absorption cooling system. *Applied Thermal Engineering* 2006; 26: 1455-1462. <http://dx.doi.org/10.1016/j.applthermaleng.2005.12.014>
- [5] Gomri R. Solar energy to drive two stage half-effect absorption cooling system. *Int. J. Thermal & Environmental Engineering* 2010;1:1-8.
- [6] Kotas JT. *The exergy method of thermal plant Analysis*. Lavoisier, Paris., 1987.
- [7] Bejan A., Tsatsaronis G., Moran M. *Thermal design and optimization*. Wiley, New York, 1996.
- [8] Patek J, Klomfar J. Computationally effective formulation of the thermodynamic properties of LiBr-H₂O solution from 273 to 500K over full composition range. *Int. J. of Refrigeration* 2006; 29: 566-578. <http://dx.doi.org/10.1016/j.ijrefrig.2005.10.007>
- [9] Patek J, Klomfar J. A simple formulation for thermodynamic properties of steam from 273 to 523 K, explicit in temperature and pressure. *Int. J. of Refrigeration* 2009; 32: 1123-1125 <http://dx.doi.org/10.1016/j.ijrefrig.2008.12.010>
- [10] Nougier JP. *Méthodes de calcul numériques*. Edition Masson, Paris, 1985.
- [11] Bakhvalov M. *Méthodes numériques*. Edition Mir, Moscou, 1984.
- [12] Demidovitch B, Maron I. *Elements de calcul numérique*. Edition Mir, Moscou, 1979.