

## Energy Rating Windows for Residential Buildings

**K. Hassouneh<sup>a</sup>, A. AlShboul<sup>a</sup>, and A. Al-Salaymeh<sup>b,\*</sup>**

<sup>a</sup>Architecture Engineering Department, Faculty of Engineering & Technology, Univ. of Jordan, Amman 11942, Jordan

<sup>b</sup>Mechanical Engineering Department, University of Jordan, Amman 11942, Jordan

### Abstract

The present paper describes an example of an energy rating windows for residential buildings in Jordan. It focuses on the thermal properties of the available windows in the market in Jordan. Windows have a great effect on the heating and cooling requirements costs of a building, and the comfort level experienced by its occupants. Windows are considered the weakest link in a building envelope for heat gain in the summertime and heat loss in the wintertime. A survey on the most common windows that are used in residential buildings has been carried out. The label of the window describes the type of window, and rates it for many factors such as U-Factor, SHGC, and visible light transmittance. The output of the present work can give the home owners an opportunity to choose the appropriate window for the building taking into consideration thermal performance of the window and its impact on the cooling and heating load of the building. The energy performance of the building and the choice of energy efficient window are dependent on glazing type, number of glazing, frame materials, interior and exterior, shading, and window orientation. Therefore, it is very important to take into consideration all options when determining which energy-efficient window is best and most cost-effective for your needs both now and in the future. The most important reason to select energy efficient windows is to reduce the annual coast of heating and cooling of the buildings. This makes good sense for the most building owners and it also contributes in the efforts to reduce the bad impacts of the non- renewable energy use.

**Keywords:** Rating Windows, Residential Buildings, Energy Balance

### 1. Introduction

Solar energy is considered the largest domestic energy source. For the long-term future, ensuring the security of energy supplies is a highly important issue, and this is regarded as a major importance relative to the more immediate problems facing Jordan. The special situation of Jordan and the present world oil price suggests that renewable energy sources such as solar energy can be adapted much better to the needs of the country. Jibril [1] pointed out that Jordan is blessed with an abundance of solar energy which range between 5-7 kWh/m<sup>2</sup> and this corresponds to a total annual value of 1600-2300 kWh/m<sup>2</sup>, e.g. Audi and Alsaad [2].

The current share of renewable energy in total energy mix in Jordan is low and it can reach 1.2% only. According to the national energy strategy, the share of renewable energy in total energy mix should be increased to 7% in 2015 and to 10% in 2020. Therefore, Jordan started a program to implement renewable energy resources such as solar energy in many applications.

Windows have a tremendous effect on the heating and cooling requirements and costs of a home, as well as the comfort level experienced by its occupants. Windows are considered as the weakest link in a home's building envelope for heat gain in summer time and heat loss in winter time. The energy performance of buildings and the choice of energy efficient windows are affected by glazing type, number of panes, window frame materials and design, interior and exterior shading, and window orientation. Therefore, it is extremely important to carefully consider all options when determining which energy-efficient window is best and most cost-effective for domestic buildings, both now and in the future. It does make a difference to use energy-efficient windows—in cost savings, in energy savings and as a benefit to the environment.

### 2. The Impact of Windows on the Overall Energy Consumption

Windows provide less resistance to heat flow than walls, ceilings, and floors of your home. Even when windows comprise a small area of a home, they are the area of greatest heat loss and gain, and air leakage. Windows can account for as much as 25-30% of the heat loss in a home. This increases energy use and costs, and decreases your comfort. The

\* Corresponding author. Tel.: +962 6 53 55 000 Ext. 22788

E-mail: [salaymeh@ju.edu.jo](mailto:salaymeh@ju.edu.jo)

© 2010 International Association for Sharing Knowledge and Sustainability

DOI: 10.5383/ijtee.01.02.002

performance of windows, walls, ceilings, and other building components determine the monthly energy cost as well as the required size of your heating and cooling equipment. The installation of energy-efficient windows (as well as other aspects of a home's construction) reduces not only your monthly energy use (and costs) but also means that a smaller, less expensive furnace and air-conditioning system will be required. Therefore, while energy-efficient windows will cost more initially, the monthly savings on your energy bills coupled with a reduction in the purchase price of the heating and cooling system, can more than offset the higher initial cost, e.g. Sekhar and Toon [3].

Windows are responsible for a disproportionate amount of unwanted heat gain and heat loss between buildings and the environment, over 3% of total energy consumption in the USA is lost through windows, in Sweden this percentage is about 7%, e.g. Collins et al. [4]. Controlling the solar heat gain could be very useful in determining the thermal performance of the building, e.g. Bouchlaghem [5].

Windows has physical and psychological benefits, which have effect on the mood health and productivity of workers in the work places (Tabet-Aoul, [6], Heerwagen [7]). There is limited understanding of the links between environmental and social or cultural sustainability but it is surely approved that well oriented and high performance windows have a tremendous effect on the conserving of energy in buildings.

A thermal bridge is one of the weakest points of the heat insulation, and it is a place in the structure with high conductivity that causes a reduction in the overall thermal insulation of the whole structure because the heat will flow from the heated space to the outside through this weak path" the thermal bridge". The main thermal bridges are caused by the presence of a conductive material crossing the insulation (metal framework in concrete or metal frame of a window) or by the walls' geometry. The ways to avoid thermal bridges in windows includes avoiding metallic frames, double glazing or more and coatings on the panes.

### 3. Energy Rating Systems of Windows

Many aspects need to be taken into account when choosing windows for a building. Some of them are shown below in Fig. 1 such as day light transmittance, visual aspects, sound, fire resistance, etc, but in this thesis we are going to focus on the energy efficiency of the windows.

Windows, skylights, and glazed doors—can account for over 25% of the heating and cooling energy bills in a typical home. Designers, builders, and homeowners have never had a tool for determining or comparing the energy performances of fenestration products to assist them in their purchase decisions. Many manufacturers offer a variety of energy-efficient products, but have not been able to demonstrate their superiority through comparable performance ratings (Huang et al. [8])

Advanced computer tools are developed in United States and Canada, and used to determine the energy ratings. Fenestration is a term used to describe an opening in a building envelope which includes windows, skylights and doors. An organization called the National Fenestration Rating Council (NFRC) began since 1993 to make window energy efficiency labels for new buildings. (NFRC) has developed a window energy rating system based on the whole product performance. The main aim of this company is to make accurate standardized information

which enables consumers to make comparison between the energy performance of different types of windows, doors and skylights. The label of (NFRC) describes the type of window, and rates it for these factors such as: U-Factor, solar heat-gain coefficient (SHGC), and visible light transmittance.

The rating of windows could be divided in two levels:

- Level 1 is to label the physical properties of the window such as the U-value, the g-value and the visual transmittance (Tvis). The NFRC in the USA has developed such a rating.
- Level 2 is to develop the energy rating as discussed above .This system yields one single figure that is labeled on the window, independent of zone and type of building. This rating favors a choice of window with a high g-value, low U-value and low infiltration, which is preferable in many cases in heating dominated (cold) climates (Amorim [9]).

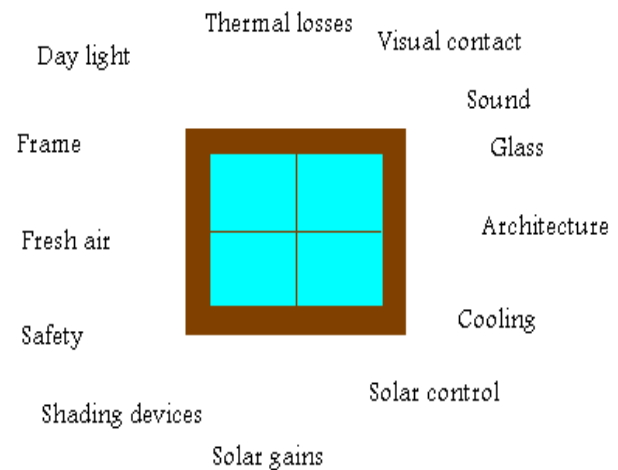

Fig. 1. Window aspects

The tools that have been used in the present research study can be summarized as shown in Fig. 2 as follows:

- 1) General resources of information with links to the subject of the study such as books, journals, proceedings, dissertations, institution publications and internet.
- 2) Survey to determine the most common windows that used in apartment buildings and study their influence on the energy balance of buildings
- 3) Scientific and mathematical equations to calculate heat gain and loss
- 4) Self Developed Software based on the ASHRAE tables and equations that calculate heat loss and heat gain, the Self Developed Soft ware is able to calculate the amount of energy saved by windows in buildings
- 5) Analyzing results from simulation using excel program
- 6) Personal communications with institutions companies and persons related to study.

### 4. Case Study

The influence of windows on the energy balance of 4X4 m<sup>2</sup> room in the apartment buildings in Amman has been studied. The schematic diagram of the room can be shown in Fig. 3. The room composed of one exterior wall of U value = 0.8 W/m<sup>2</sup>.K, and three interior walls with U value = 1.9 W/m<sup>2</sup>.K, one window is located in the exterior wall. Calculations are made for Amman city, Latitude 32 °N. Windows are supposed to be located in the main directions (N, S, E, W). The energy saving is calculated for winter season (January, February, March, April, November, December). The study has been carried out by making variations on the type of glazing, area of glazing, and orientation. Self Developed software is used to calculate solar heat gain due to fenestration and to define the influence of the glazing area on the amount of energy saving in the building. In the second step, energy saved due to fenestration of the whole apartment is calculated.

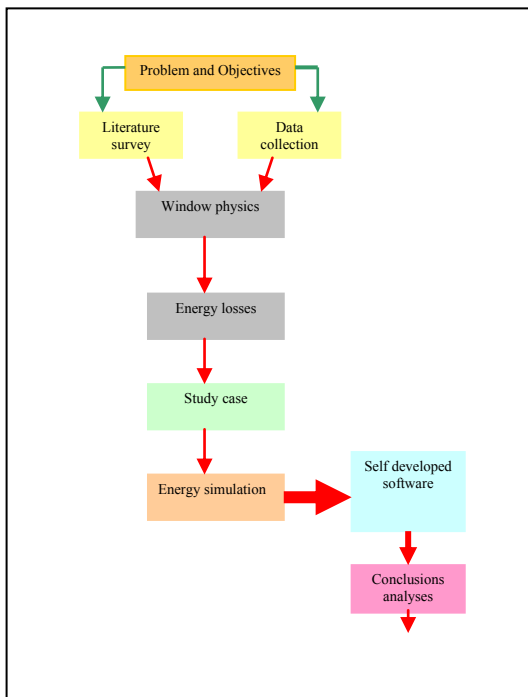

Fig. 2. Research Methodology

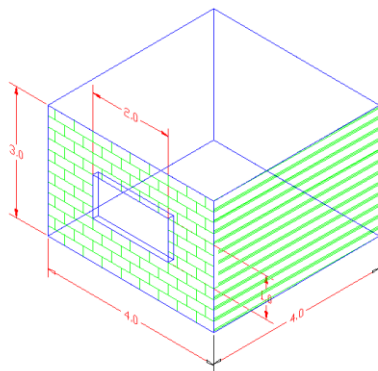

Fig. 3. A room of 4X4 m<sup>2</sup> with one exposure wall that has a window of 2 m<sup>2</sup> area.

A list of officially registered local manufacturers of windows was obtained from Amman Chamber of industry. There are

about 500 manufacturers who produce aluminum doors windows and frames, some manufacturers use profiles produced locally. Others use imported profiles from Europe and other countries, there are large number of black smiths and carpenters that produce steel and wooden doors and windows, about 900 manufacturers produce iron and steel windows doors and frames, wooden doors and windows manufactures are more than 1000 manufacturers. Several houses in Amman are visited to investigate types and profiles of windows installed in these houses.

Energy performance of eight window types is investigated. These types are classified according to the main component of the glazing unit into eight types ranges from A to G. These types are discussed in details in Hassouneh et. al. [10]. Therefore, the details of these types can be found in reference [10]. The reference glass has been chosen to be the clear glass. The details about the properties of the reference glass type and the difference temperature between the inside and outside as well as the number if operation hours for the heating or cooling system can be found in Hassouneh et al. [10].

The building construction consists of typical stone walls, the wall construction consists of stone, concrete, insulation, concrete blocks, and plaster as shown below in Fig. 4, and the ceiling is also insulated using hollow concrete blocks as shown below in Fig. 5. "U" values of some construction components used in the building are listed below in Table 1.

Table 1. U values of construction components

Component	"U" value W/m <sup>2</sup> °C
Exterior wall	1.8
Windows	6.7
Exterior door	3.5
Insulation used in exterior walls	0.9

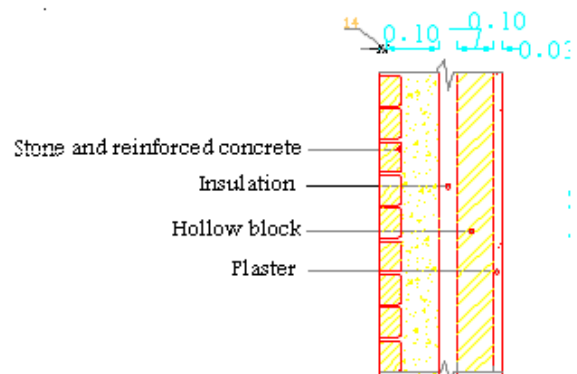

Fig. 4. External wall details

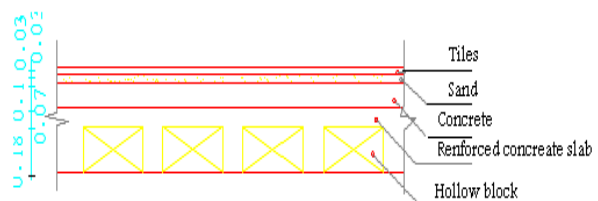

Fig. 5. Ceiling details

### 5. Simulation Tools

In the present work, a software based on excel program has been developed to perform direct heat gain due to solar radiation. The software helps designers to define the energy efficiency of windows, and to compare different windows without having access to detailed information about the building but still take into account the type of building and the type of glazing. This program is developed depending on the energy equations and the ASHRAE tables of solar heat gain and cooling factor of glass in different directions. The Input data required for the calculations as well as the output data of SDS program are listed below in Fig. 6 and a schematic flow chart of SDS are illustrated below in Fig. 7.

Hassouneh et al. [10] discussed that fenestration is a source of thermal load that needs to be cooled. The winter season in Amman is started in November till April. The solar heat gain depends on maximum solar heat gain factor (SHG), shading coefficient (SC) and the cooling load factor (CLF), e.g. [10]. The self-developed software has been used to make the required calculations, e.g. [10]. Similar calculations can be repeated by considering the south wall as an exposure wall and keep all conditions as they considered for the north wall. The heat loss due to the wall, glass and infiltration are similar to that case of north wall, but the heat gain due to the solar energy will be changed.

The results for south wall are completely different from that of north wall. A huge quantity of energy saving can be obtained from solar energy if we designed a window in the south direction. The energy saving is calculated for eight types of glazing (Clear glass, Type A, B, C, D, E, F, G) and for glazed area varied from 0 to 12 m<sup>2</sup> (the whole wall area) for winter in four orientations (North, South, East, West).

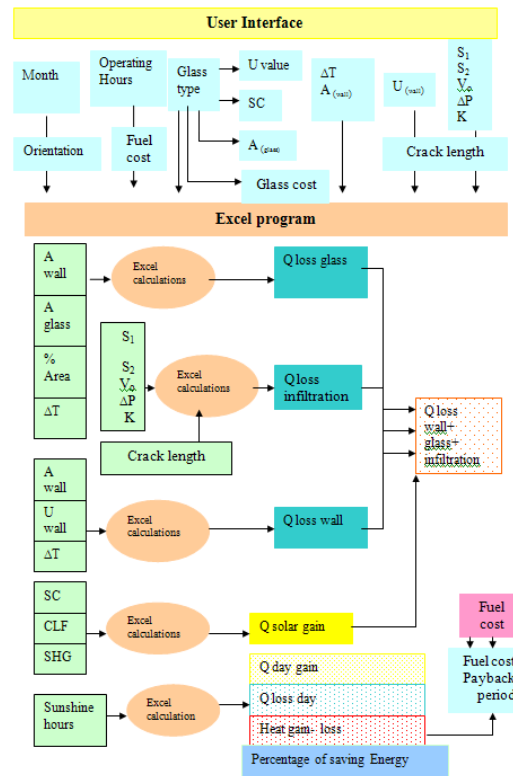

Fig. 7. Schematic flow chart of SDS

The cost of fuel consumption can be calculated based on the current cost of the diesel. Finally, the payback for the cost of glazing can be calculated by dividing the cost of glass over the amount of money which can be saved each year in winter season by utilizing the solar energy. The interest rate which is about 10% can be assumed to be similar to the expected yearly increase in the diesel cost.

### 6. Results

The simulations results for the influence of the glazed area on the energy balance of a building are discussed in this section. Also, the influences of the other factors such as orientation, type of glazing, climate and comfort on the choice of window area are investigated and the results are discussed and presented. It is found that some types of glazing can save more energy than other types, and some types of glazing are more efficient in a specific direction than others. Also the effect of the ratio of the glazing area with respect to the wall area on the energy saving of different types of glazing has been investigated and the results are shown in the coming parts of the thesis.

As it was mentioned previously, the energy saving has been calculated as a ratio between the net energy gain (heat gain from solar energy through glazing area – heat loss from the glazing area) divided by the total energy losses from the wall and glass. The total area of the wall was selected to be 12 m<sup>2</sup> and the glazed area was changed from 0 m<sup>2</sup> (no window) till 12 m<sup>2</sup> (full glazed area).

Fig. 8 shows the effect of using clear glass on the percentage of energy saving as a function of glazed area for all main directions with infiltration. By using energy simulations, it has been found that the clear glass is very effective in the south,

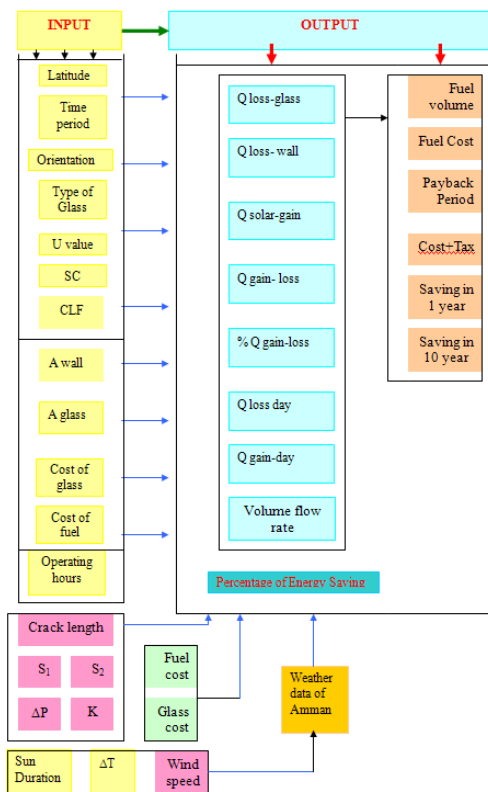

Fig. 6. Input and Output data of SDS

west and east directions. Also, It is found that the percentage of energy saving is increased as the percentage of glazed area in the exposure wall increases. This relationship between the saving energy and the glazed area is reversed for north direction. As the glazed area of clear glass in the north direction increases, the energy saving decreases and the energy losses increases as shown in Fig. 8. The negative sign of the energy saving in the north direction means that the energy losses are higher than the energy savings. As the results in Fig. 8 shows, the clear glass type is not suitable to be used for the windows in the north direction because the energy losses will be very high.

In addition to the above results, a comprehensive comparison for eight types of glazing is made to compare the amount of energy saving for each type in each direction and for variable area of glazing to find guide for designer to choose the energy efficient windows. A comparison of the energy saving or losses for the eight types of glazing which are used in the north direction for a wall area of 12 m<sup>2</sup> and for a glazing area ranges from 0 to 100% is shown in Fig. 9. This figure shows the percentage of energy saving or energy losses as a function of the glazed area with respect to the wall area for different types of glazing and for the north directions. By carrying out energy simulation for each glazing type and area, it is found that glass type B can save the largest amount of energy in the north direction so it is very efficient to be used in the north elevations. Also, glass type D is preferable in the north direction because of its ability to save energy in winter in the presence of infiltration as shown in Fig. 9. The other types of glasses are not energy efficient in the north direction. The energy saving increases by increasing the window area for type B, but if the other types of glasses are used in the north direction, then more energy losses can occur as the glazing area increases. Therefore, it is recommended to reduce the window

area for minimum size if the other types of glazing are used in order to reduce the heat losses from the heated space.

On the other hand, if a glazing window is used in the south direction, then energy saving can be obtained for all types of glazing as shown in Fig. 10. The results for energy simulations are presented in Fig. 10 for eight types of glazing installed at the south direction of a wall which has an area of 12 m<sup>2</sup> and the area of glazing ranges from 0 to 12 m<sup>2</sup>. Also, it has been found that increasing the window area in the south direction can save more energy for each type of glass. In addition, increasing the glazed area facing south decreases the heating demand if low-e windows are used.

The selection of the optimum window size for each direction depends not only on the amount of energy saving provided by the window but also on the cost of glazing and the amount of money saved. Therefore, the best type of window from the energy point of view can be described as follows as those who saves energy, reduces heat loss; saves money and has low cost. The data in Figs. 9 and 10 does not show the capital cost of the glazing and therefore it cannot be taken as a guide for selecting the best type of glazing. Usually, a payback period can be taken as guide for selecting the economic type of glazing. Fig. 11 shows a comparison of the payback period for cost of each type of glazing in the south direction as a function of the glazing area. The comparison shows that the payback period of clear glass is less than other types, while the payback period of glass type A and B is reasonable. It is recommended to use glass type A in the south direction even that its payback period is 5 years and the payback period of clear glass is 2 years. Clear glass can be used frequently, but glass type A can save more energy and therefore more money than clear glass and it is more feasible for long period of time. Glass type C or F or G is not recommended to be used in the south direction because of its payback period is too high as shown in Fig. 11.

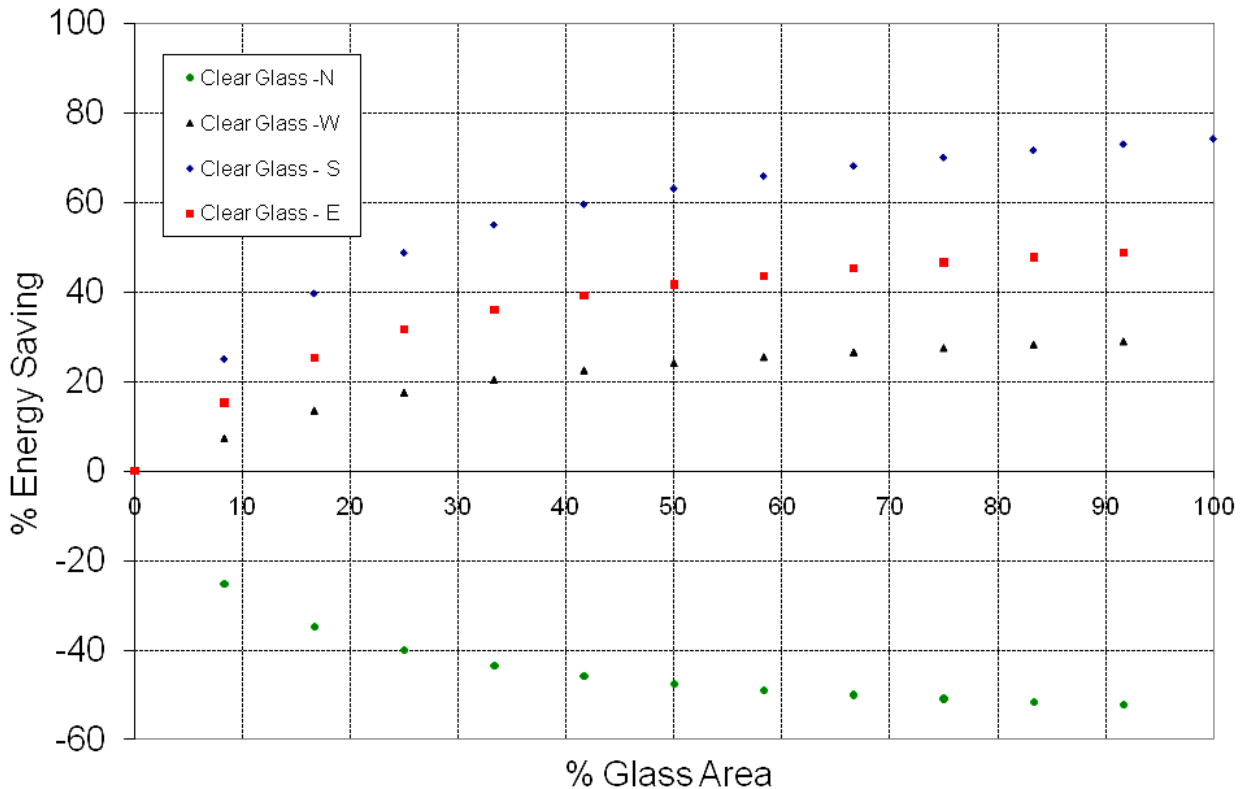

Fig. 8. The effect of using Clear glass on the percentage of energy saving as a function of glazed area with infiltration

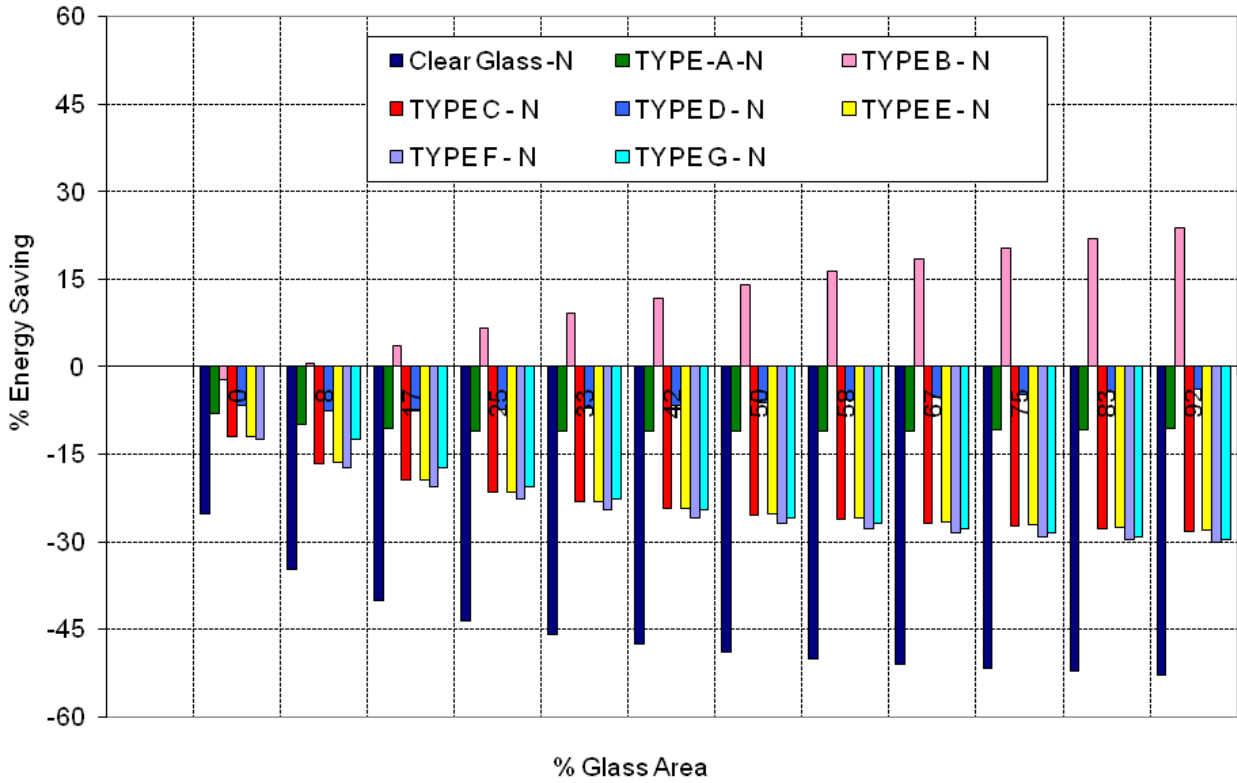

Fig. 9. Energy saving or losses in the north direction as a function of glazed area for eight types of glasses in the presence of infiltration

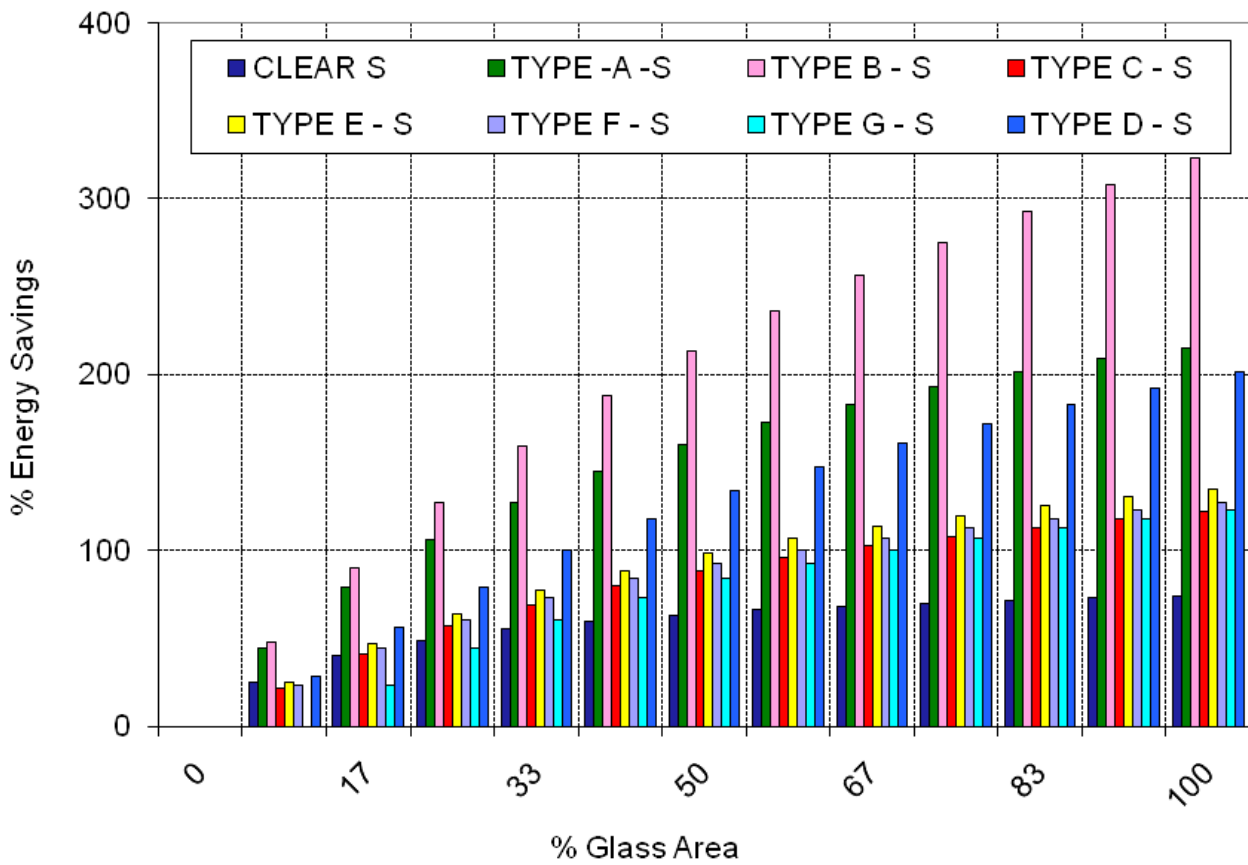

Fig. 10. Energy saving or losses in the south direction as a function of glazed area for eight types of glasses in the presence of infiltration

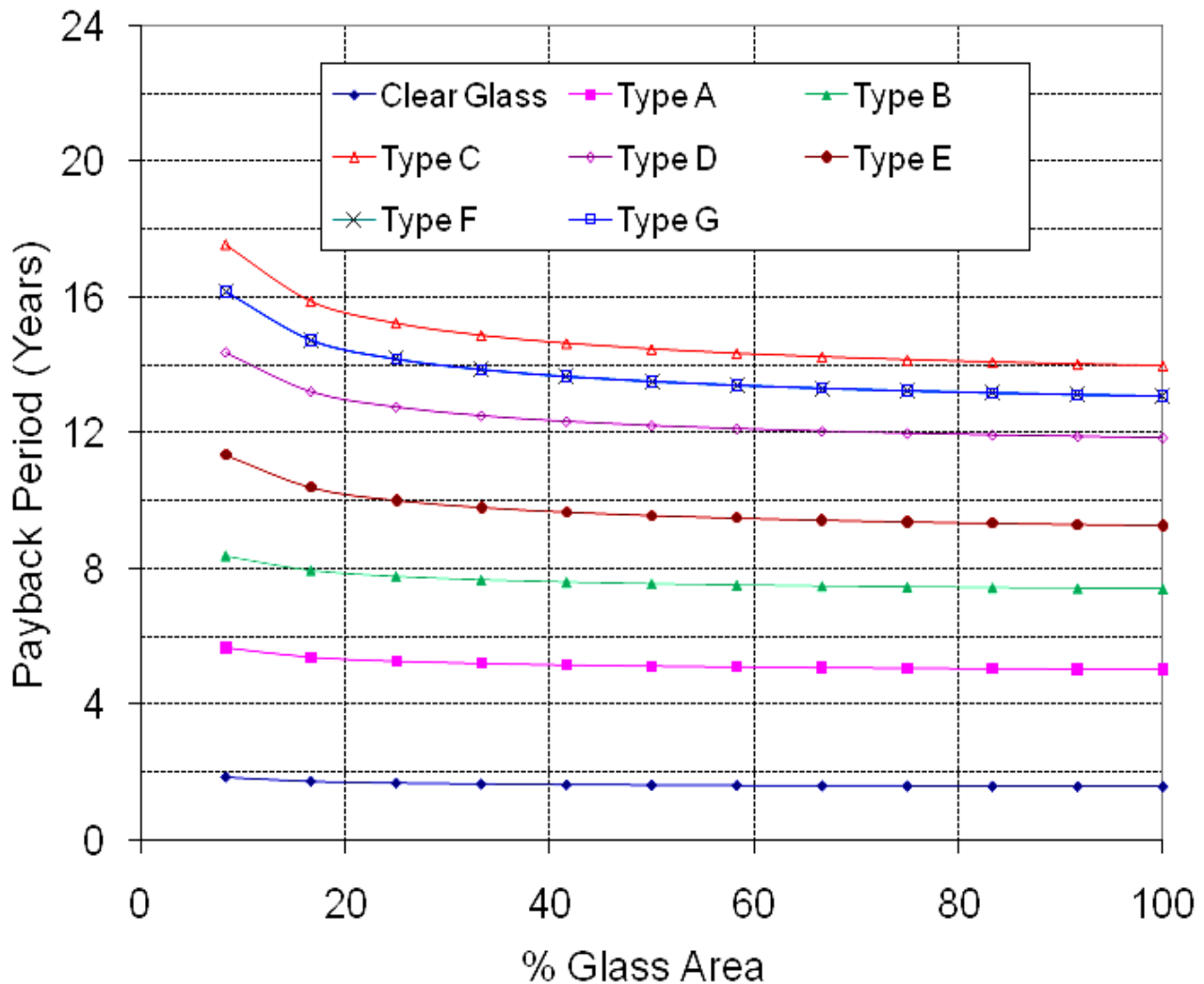

Fig. 11. The amount of saved money as a function of glazing area for different types of glazing in the south direction

### 7. Conclusion

The results show that some types of glazing are more efficient in a specific direction than others. The best type of window from the energy point of view is that the windows that can save energy, save money, reduce heat loss, and its cost is low.

By using energy simulations, it has been found that the clear glass is very effective in the south, west and east directions. Also, it is found that the percentage of energy saving increases as the percentage of glazed area in the exposure wall increases. On the other hand, this type is not suitable to be used for the windows in the north direction because the energy losses will be very high. Glass type A can save three times higher energy than clear glass in the south direction. The energy saved by using glass type B reaches approximately five times the energy saving using clear glass in the south direction which can reduce the heating load in winter. This type of glazing (type B) can also save a good amount of energy in the north direction which makes it very suitable to be used in the north elevations or orientations of buildings.

The using of glass type C in the north direction causes losses in energy reaches 20% when the wall is totally glazed but it is more effective in the south direction and the energy saving increases with the increased area of glass. The amount of energy saving in the case of glass type D is better than clear glass in all directions. Glass type D can be considered in the second choice after glass type B for north direction. Types E F and G have approximately the same amount of saving energy in all directions. Their higher than the clear glass and their energy saving is about double than clear glass.

Some types of glasses are more efficient than others and the most types of glazing losses energy in the north direction except type B which can save a reasonable amount of energy in the north direction. It has been found also that, increasing the glazing area for each type of glazing in the east and west directions can provide a good opportunity to save energy.

## References

- [1] Jibril Z. Estimation of solar radiation over Jordan-predicted tables. *Renewable Energy* 1999, 1(2): 287–292.
- [2] Audi M and Alsaad M. A general model for the prediction of hourly diffuse solar radiation. *Solar Energy* 1991 10 (1): 39–45.
- [3] Sekhar SC and Toon KLC. On the study of energy performance and life cycle cost of smart window. *Energy and Buildings* 1998, 28: 307–316. [http://dx.doi.org/10.1016/S0378-7788\(98\)00026-7](http://dx.doi.org/10.1016/S0378-7788(98)00026-7)
- [4] Collins RE, Turner AC, Fischer-Cripps AC, Tang J-Z, Simko TM, Dey CJ, Clugston DA, Zhang Q-C, and Garrison JD. Vacuum glazing—A new component for insulating windows. *Building and Environment* 1995, 30 (4): 459–492. [http://dx.doi.org/10.1016/0360-1323\(95\)00025-2](http://dx.doi.org/10.1016/0360-1323(95)00025-2)
- [5] Bouchlaghem NM. A computer model for the design of window shading devices. *Building Research and Information* 1996, 24 (2): 104–107. <http://dx.doi.org/10.1080/09613219608727509>
- [6] Tabet-Aoul K. The impact of Access to Windows on Visual Comfort, Across Cultural Comparison. University of Science and Technology, Oran, Algeria, 2004, Retrieved from <http://www.caed.asu.edu/msenergy/Neeraji/Tabet.df>
- [7] Heerwagen J. Do Green Buildings Enhance the Well Beings of Workers?. *Environmental Design & Construction* 2004, from <http://www.edcmag.com/cda/articleinformation/coverstory/bnpcoverstoryitem/0.4118.19794.00.html>
- [8] Huang YJ, Mitchell R, Arasteh D, and Selkowitz, S. Residential Fenestration Performance Analysis Using RESFEN 3.1. Proceedings of thermal performance of the exterior envelopes of buildings, Clearwater, FL, 1998.
- [9] Amorim J. WinSelTM A general window selection- and energy-rating tool. 2007.
- [10] Hassouneh K, Alshboul A, and Al-Salaymeh A. Influence of Windows on the Energy Balance of Apartment Buildings in Amman. *Energy Conversion and Management*, 2010, 51(8), 1583-1591 .